

THIS DRAWING IS UNPUBLISHED. RELEASED FOR PUBLICATION
 © COPYRIGHT - By - ALL RIGHTS RESERVED.

LOC		DIST		REVISIONS			
P	LTR	DESCRIPTION	DATE	DWN	APVD		
AA	00	B1	REVISED PER ECO-11-005033	23MAR11	RK	HMR	

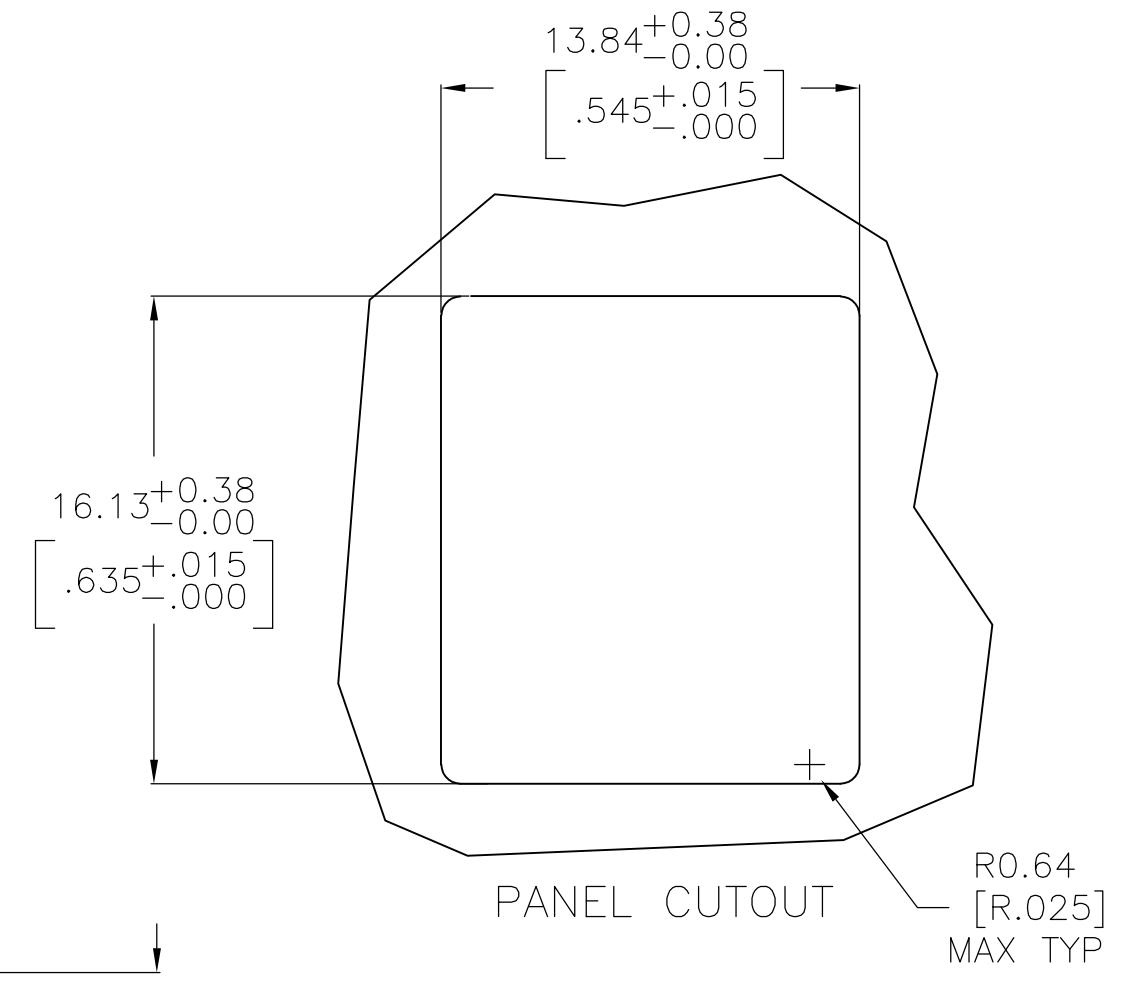
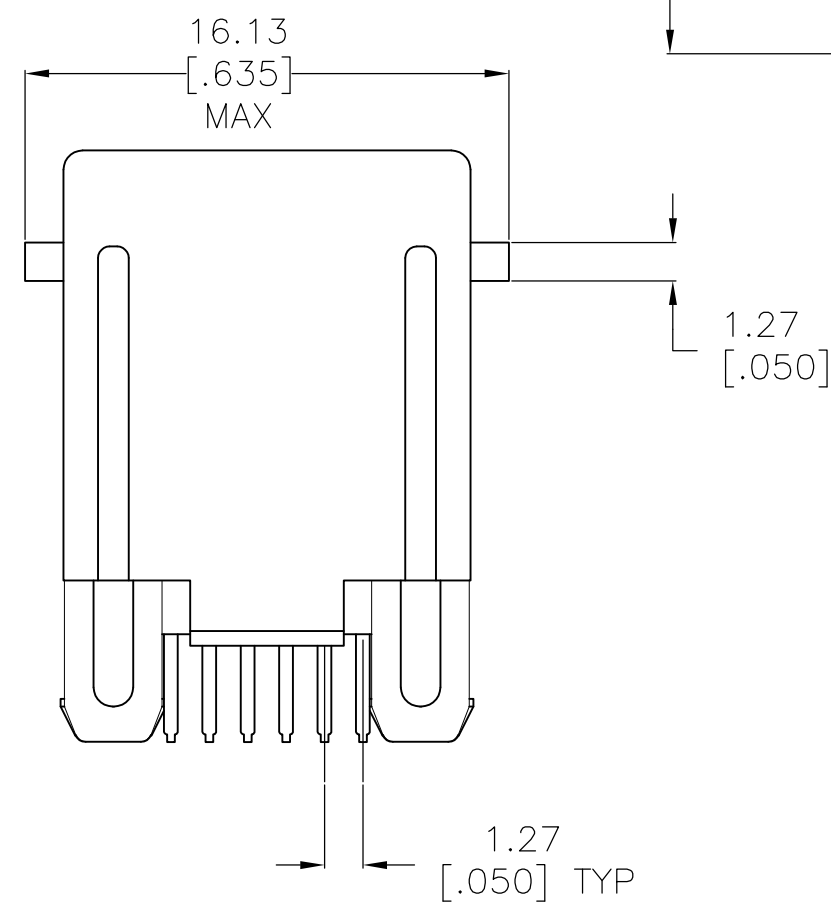
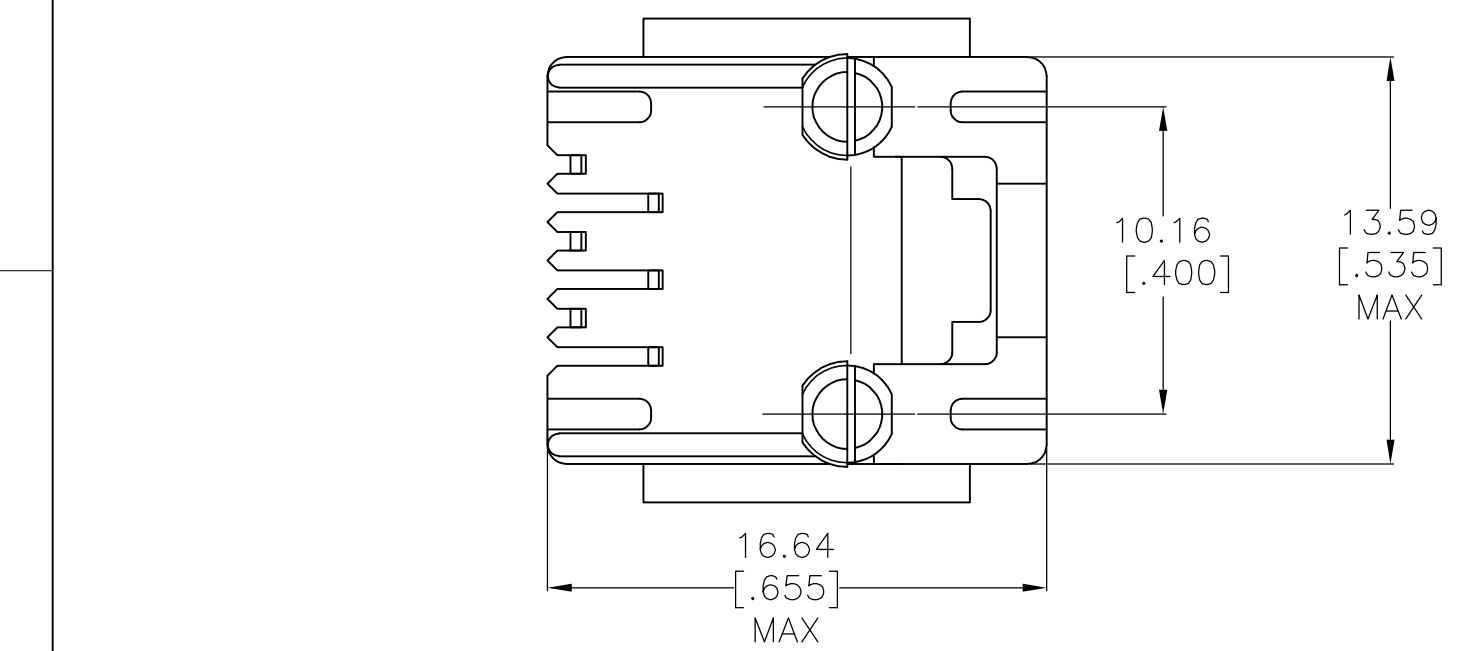
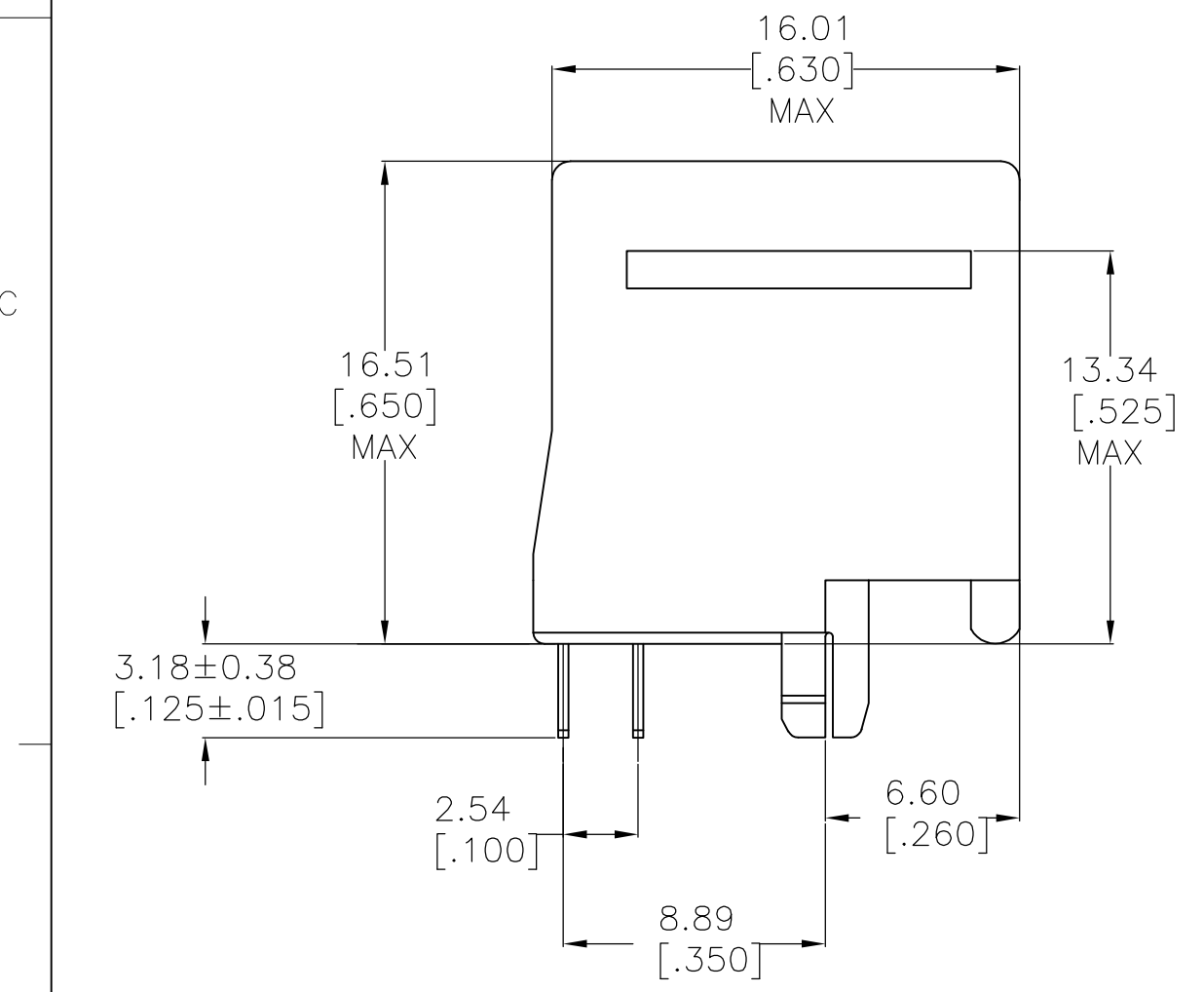
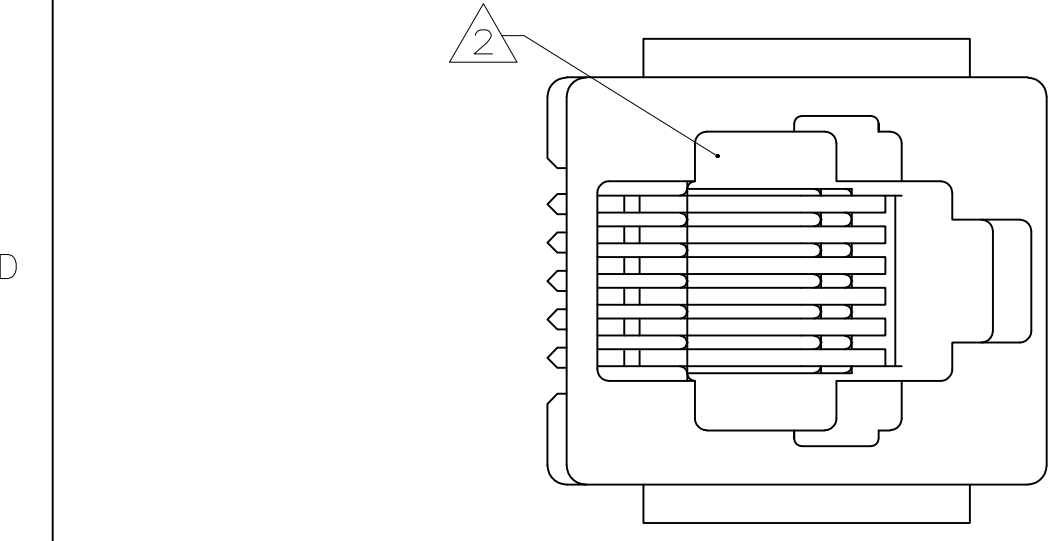

1. MATERIAL: HOUSING - BLACK PBT POLYESTER, BLACK, UL 94V-0.
 TERMINAL - 0.36 [.014] THICK PHOS-BRONZE PLATED WITH 1.27µm [.000050] MINIMUM THICK GOLD IN LOCALIZED AREA AND 3.81µm [.000150] MINIMUM THICK MATTE TIN IN SOLDER AREA OVER 1.27µm [.000050] MINIMUM THICK NICKEL UNDERPLATE.

- ⚠ JACK CAVITY CONFORMS TO FCC RULES AND REGULATIONS PART 68 AND REA BULLETIN 345-81, PE-76 SPECIFICATION FOR MODULAR TELEPHONE HARDWARE.
- ⚠ BULK PACKAGE IN A TRAY
- ⚠ PACKAGED 28 PIECES PER TUBE

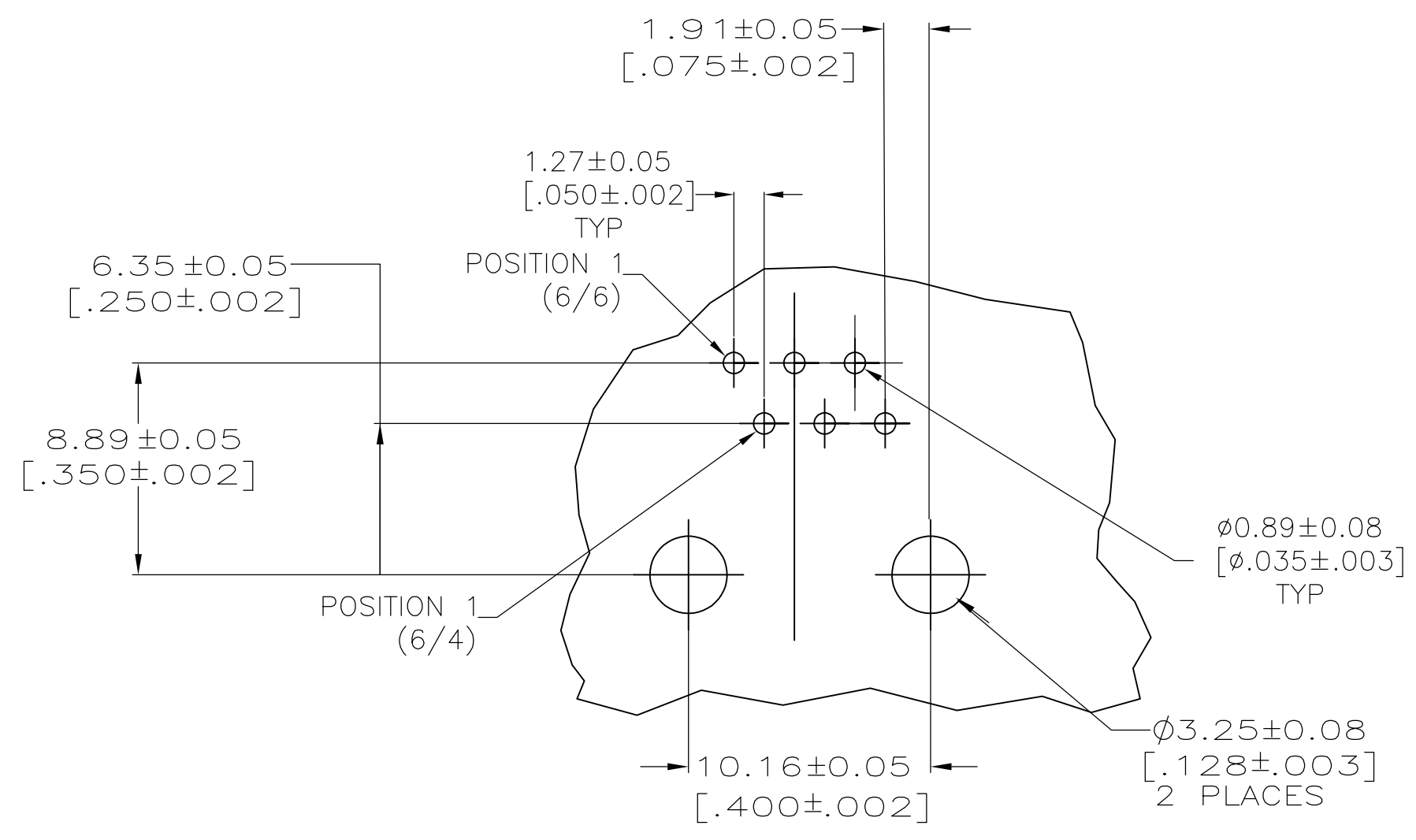

SUGGESTED PC BOARD LAYOUT
 COMPONENT SIDE

⚠	6	5520258-4
	6	5520258-3
	4	5520258-2
PACKAGED	CONTACTS	PART NUMBER

THIS DRAWING IS A CONTROLLED DOCUMENT.		DWN	L.A.MAYER	16AUG2007	 TE Connectivity
DIMENSIONS: mm [INCHES]		CHK	P.RECCE	16AUG2007	
TOLERANCES UNLESS OTHERWISE SPECIFIED:		APVD	S.FLICKINGER	16AUG2007	
0 PLC ± - 1 PLC ± - 2 PLC ± 0.13[.005] 3 PLC ± - 4 PLC ± - ANGLES ± - FINISH SEE NOTE 1		PRODUCT SPEC	108-1163	NAME	
MATERIAL SEE NOTE 1		APPLICATION SPEC	114-2048	SIZE	A2
		WEIGHT	-	CAGE CODE	00779
		CUSTOMER DRAWING		DRAWING NO	C=5520258
				RESTRICTED TO	-
				SCALE	4:1
				SHEET	1 OF 1
				REV	B1